

SOFTWARE HOUSE *Model SWH-2400*

*Extended Range Contactless
Smart Card 13.56 MHz
Reader Installation Guide*

**Version A0
Part Number UM-106
August 2007**

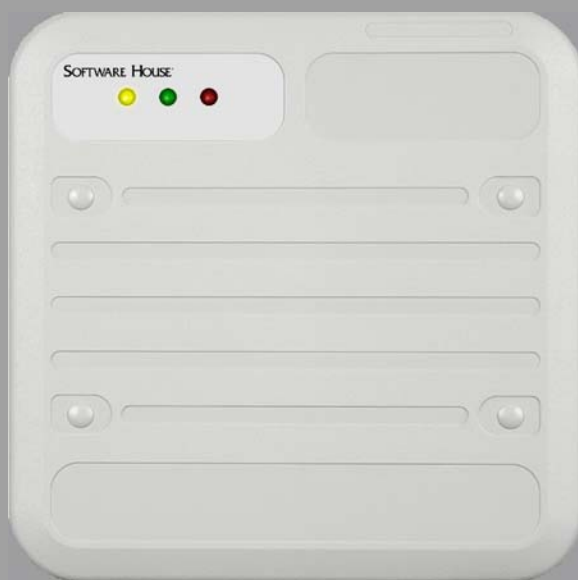

CONTENTS

Introduction	3
Features	4
Mounting Instructions	5
Environmental Factors	6
Using SWH-2400 in Parking Applications	10
Wiring to Interface Connector	15
Installation Notes	17
Tuning the SWH-2400	18
Model SWH-2400 Technical Specifications	20
Troubleshooting	22
Canadian Radio Emissions Requirements	31
CE Marking	32
Copyrights and Trademarks	34

INTRODUCTION

The SWH-2400 reader reads Smart Cards at a frequency of 13.56 MHz. The reading capability includes both serial numbers and programmed sectors, as well as encrypted and unencrypted ID data.

Compatible standards include ISO 15693, ISO 14443A, ISO 14443B, and MIFARE® sector. Refer to Table 1 for a complete list of compatible standards and data.

TABLE 1. Read Capability:

ISO 15693 (Serial Number)
ISO 14443A MIFARE (Serial Number)
ISO 14443B (Serial Number)
HID <i>iCLASS</i> ® (Serial Number)
DES <i>Fire</i> ® (Serial Number) including early TWIC standards. Note: TWIC is presently undergoing review and future standards may or may not be read, or may be read only with firmware upgrades.
MIFARE Encrypted Sector, using SWH keys and custom keys, reading SWH format, C•CURE format, and custom format.

FEATURES

- Wiegand signaling output
- ISO 15693 & 14443A/B compliant
- Outdoor/Indoor Use
- Unique Easy-Tune adjustment improves performance and reduces the impact of nearby metallic objects, enabling the reader to achieve optimum performance no matter what the mounting environment.
- Extended Range
 - ◆ Nominal 200 mm (8 in) for ISO 14443A/B cards (MIFARE)
 - ◆ Nominal 250 – 300 mm (10 - 12 in) for ISO 15693 cards (iCLASS)
- Plug In Screw Terminals
 - ◆ External Beeper Control
 - ◆ Power and Ground
 - ◆ Tamper contact
 - ◆ Two Wire Wiegand (Data 1 and Data 0)
 - ◆ External Green LED Control
 - ◆ External Red LED Control
- Universal compatibility with all ISO 15693 and ISO 14443A/B credentials (badges, disk tags and key fobs). Reads most 13.56 MHz credentials.
- Reverse polarity diode protection on power lines.
- High-speed transient voltage suppressor diodes on data lines.
- IP65-rated sealed electronics for deployment in both interior and exterior environments.
- Integrated reader tamper protection

MOUNTING INSTRUCTIONS

When mounting Model SWH-2400 extended-range Smart Card readers, consider the reader dimensions, how the readers are mounted and their proximity to other equipment, including other readers, and structural elements, whether visible or hidden.

Backplate Mounting Dimensions

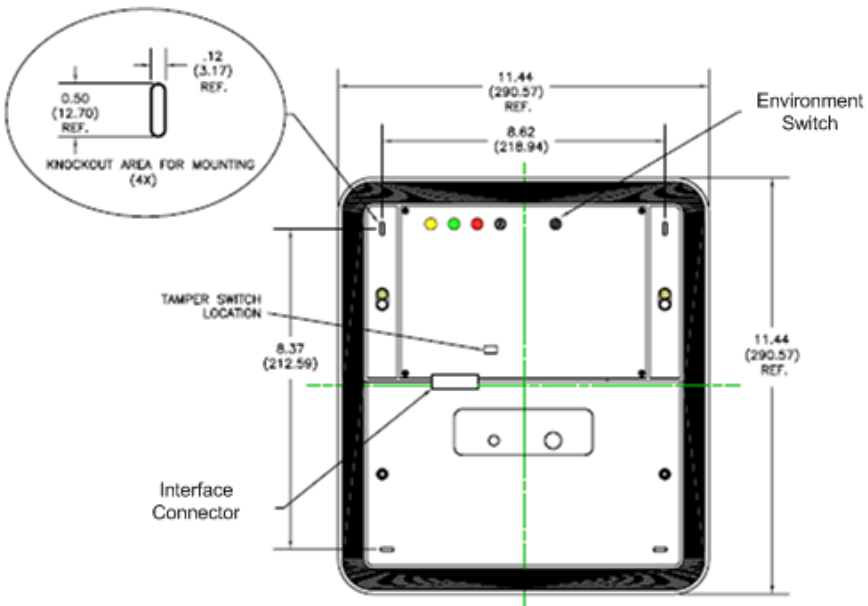

FIGURE 1. Backplate Dimensions

Environmental Factors

These environmental factors can interfere with SWH-2400 readers:

- Electrical Noise (field wiring related)
- Field Blocking (conductive material in read field)
- Overlapping Fields (other nearby readers)

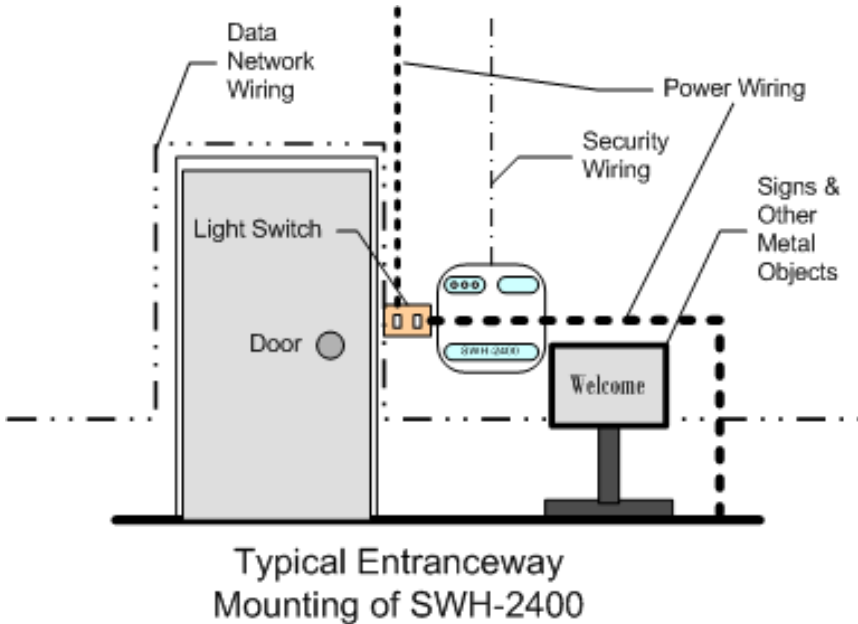

FIGURE 2. Mounting SWH-2400 in a Complex Environment

Figure 2 shows environmental factors that can interfere with typical reader installations. For example:

- **Power Wiring** carries electrical noise which can interfere with operation of the reader. Although this interference is common with older 125 KHz readers, modern facilities can also couple data noise into the power wiring, which interferes with operation of the reader.
- **Data Network Wiring** can generate noise in the operating range of the RFID. This noise can interfere with reader/credential communication and reduce read range.
- **Security Wiring** is not normally a source of noise itself. However, if the wiring is bunched in a loop directly behind the reader, it can transfer noise into the reader by inductive or capacitive coupling to data or power wiring.
- **Signs and Other Metal Objects** within the read field of the reader can absorb or block RF energy and reduce read range.

Readers that are mounted directly on a metal plate or other electrical conducting substance may see a reduction in expected read range, even when tuned for optimal performance.

For the maximum read range, make sure that the back of the Model SWH-2400 reader is at least 150 mm (6 inches) from any conducting surface.

Mounting Readers Near Each Other

A potential source of interference is caused by mounting two or more readers near each other, as shown in Figure 3.

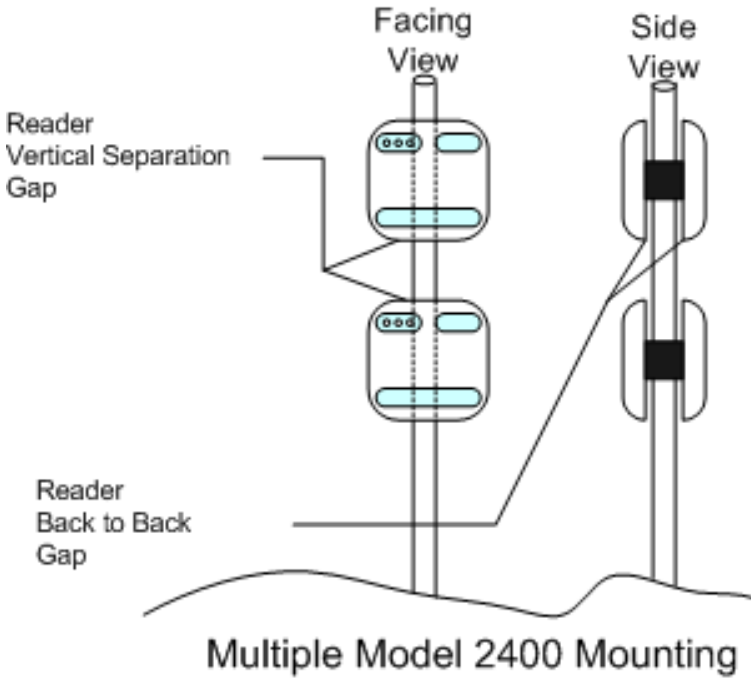

FIGURE 3. Pole Mounted Readers

When multiple readers are mounted near each another, two problems may occur:

- ◆ The signal energy from one reader can interfere with the read range of another.
- ◆ A single credential may be read simultaneously by two or more readers as a result of overlapping read fields.

To ensure proper operation and maximum read range:

1. Mount all readers first before tuning any of the reader antennas.
2. Ensure that the Back to Back Gap is at least 1 meter (39 inches).

NOTE: A narrower Back to Back Gap of 500 mm (20 inches) can be used only if you can accept simultaneous readings of a credential by two or more readers.

NOTE: If a metal plate exists between the two reader backs, you can ignore the Back to Back Gap restriction; however, you must consider the minimum distance from a metal plate.

3. Ensure that the Vertical Separation Gap is at least 500 mm (20 inches). A narrower vertical separation gap of 300 mm (12 inches) may be used only if you can accept simultaneous reading of a credential by two or more readers.

Using SWH-2400 in Parking Applications

A common use for the Model SWH-2400 is in parking applications; however, the parking application presents opportunities for all the types of interference noted previously.

Figure 4 shows a typical layout of the Model SWH-2400 parking application.

In Layout A, the installation technician needs to observe both the Back to Back Gap and (if used) Vertical Gap guidelines. Mount all readers and all other structures before tuning the antenna.

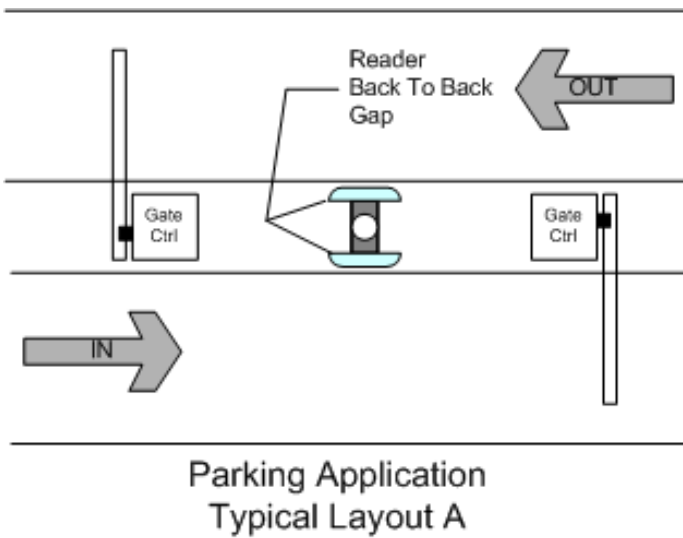

FIGURE 4. Model SWH-2400 Parking Application - Layout A

Figure 5 shows another version of the Model SWH-2400 parking application.

In Layout B, the installation technician must be more concerned about noise from the gate control mechanism and its associated wiring than from reader interference.

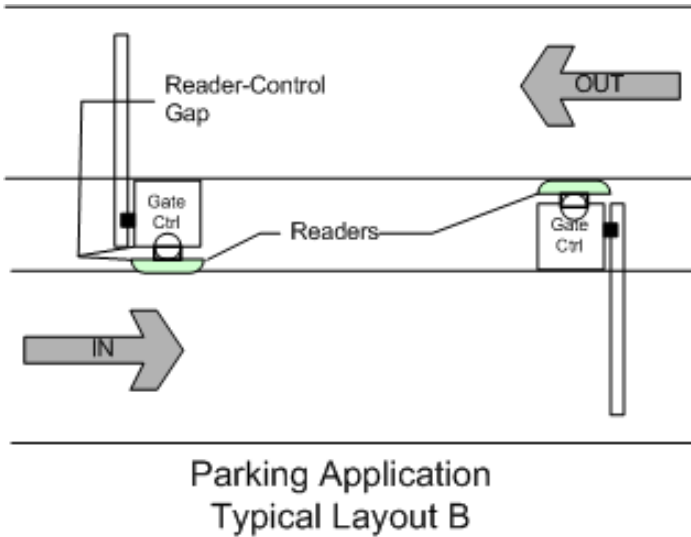

FIGURE 5. Model SWH-2400 Parking Application - Layout B

Figure 6 shows a version of the Model SWH-2400 parking application with metal signs common in both indoor and outdoor applications. The signs can be free-standing (see Figure 2) or in fixed positions (see Figure 6).

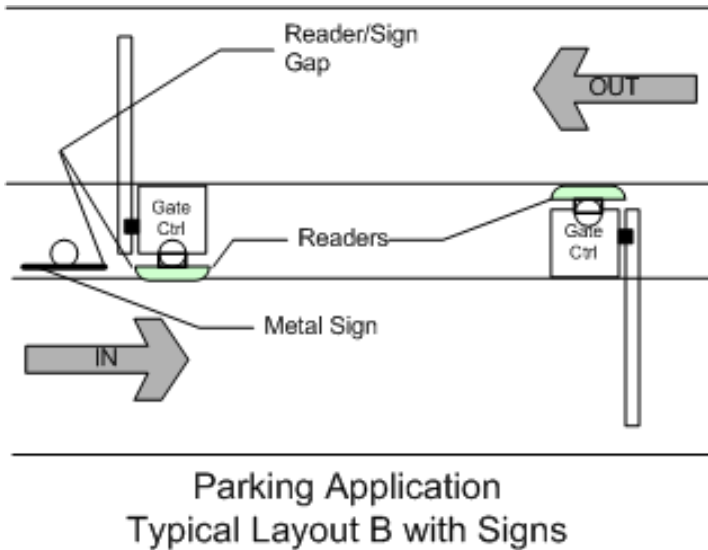

FIGURE 6. Metal Signs Affect Reader Applications

To ensure optimal read performance, make sure all signs and other conductive objects of any size are placed at a distance at least:

- ◆ 500 mm (20 inches) to the front of the reader.
- ◆ 150 mm (6 inches) to the back of the reader.
- ◆ 100 mm (4 inches) to the side of the reader.

Optimal Read Range

The reader may be mounted near metal or directly to a metal plate.

Table 2 shows how the optimal read range will improve as the distance of the metal from the reader increases.

TABLE 2. Read Range as Percentage of Optimal Range

Read Range as Percentage of Optimal Range		
Distance of Reader from Metal	ISO 15693	MIFARE® ISO 14443A
> 150 mm	100%	100%
> 100 mm	90%	85%
> 75 mm	85%	80%
> 50 mm	80%	75%
> 25 mm	75%	65%
> 10 mm	70%	60%
> 0.0 mm	65%	55%

Mounting Cover

Dimensions

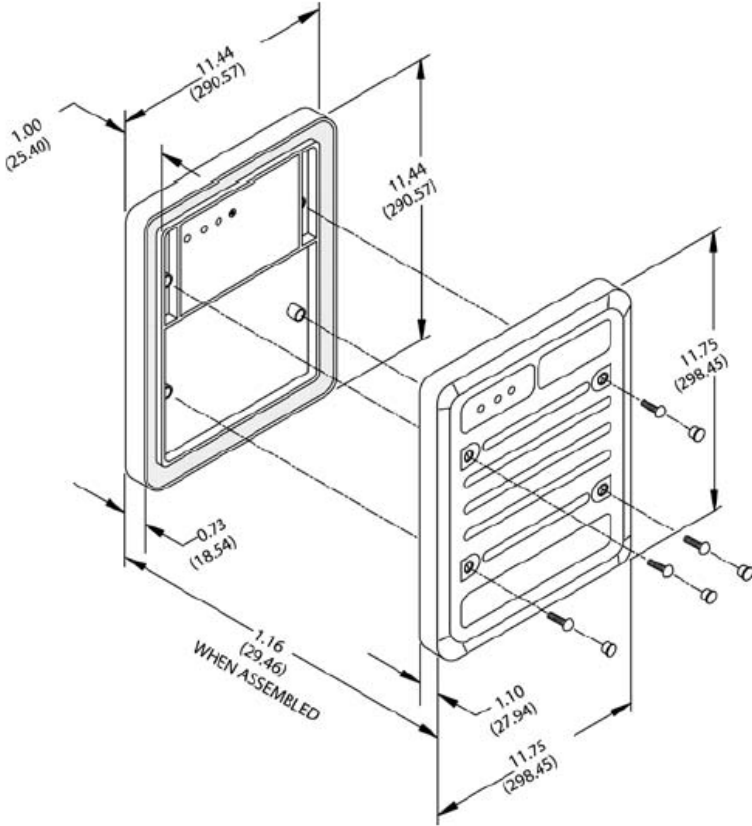

FIGURE 7. Backplate and Cover

Dimensions shown in inches (mm)

WIRING TO INTERFACE CONNECTOR

The Model SWH-2400 has twelve screw terminals as noted in Table 3. The terminal strip is removable for easy installation and wiring. When attaching a wire to the connector, strip off only the minimum insulation required (approx. 3/16"). Push the wire into the connector until the insulation is inside the green connector body but not in the metal conductive part of the connector. This is critical for outdoor readers.

The reader itself is designed and protected to IP65 standards; however, the cable wires can potentially corrode and/or short together if not carefully mounted and tightly fastened in the connector body.

TABLE 3. Connector Pins for Model SWH-2400 (12 Pin Terminal)

Pin	Description	Pin	Description
1	External Beeper Control	7	External Green LED Control *
2	Ground	8	External Red LED Control *
3	Power (8 to 30 VDC)	9	RS485-A, used for Flash upgrade
4	D1 Wiegand	10	RS485-B, used for Flash upgrade
5	D0 Wiegand	11	Tamper (Normally Closed)
6	No Connection	12	Tamper (Normally Closed)

NOTE

* It may be necessary to temporarily remove the LED drive wires from pins 7 and 8 before tuning. See “Tuning the SWH-2400” on page 19.

Table 4 indicates the maximum wiring distances according to the SIA Wiegand standard with the three most common gauges of cable.

TABLE 4. Maximum cable distance for 18, 20, or 22 AWG wire

Wire Gauge	18 AWG	20AWG	22 AWG
Cable Distance	500 feet (150 meters)	300 feet (90 meters)	200 feet (60 meters)

INSTALLATION NOTES

Follow these guidelines unless specified otherwise in this manual:

1. Shielded cable is recommended in electrically noisy environments. Connect cable shields to ground at only the controller end.
2. Use a local power supply for the reader. Do not connect the power supply from the controller to the reader. The ground line of the local power supply must be connected to the power supply of the controller. Switched power supplies are not recommended as they generate noise which can interfere with the RFID communication.
3. Because of the reader's high-power requirements, we recommend using a separate local power source with limited power consumption according to EN 60950-1 (2003) paragraph 2.5.

Das Gerät ist mit einer Stromquelle mit begrenzter Leistung nach EN 60950-1 (2003) Absatz 2.5 zu betreiben.

4. For tamper wiring, connect Pins 11 and 12 to a normally closed supervised input, as shown in Figure 8.

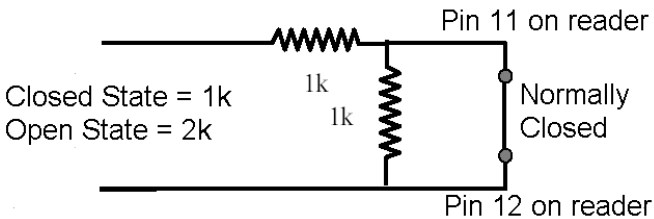

FIGURE 8. Normally Closed Supervised Wiring for Reader Tamper

Tuning the SWH-2400

The SWH-2400 reader can be field-tuned to accommodate installation on or near metal surfaces. To tune the SWH-2400:

1. Remove the front cover.
2. Environment selection switch. Set the Environment two-position slide switch to the **UP** position (**> 20 mm distance from metal**).
3. Press the **Tune** button and release when the reader beeps. This places the reader into the tuning mode. It will stay in this mode for approximately 90 seconds.
4. A blinking Green LED indicates that the reader is tuned successfully.
 - ◆ If the Green LED blinks, do nothing.
 - ◆ If the Yellow LED blinks, turn the tuning switch **LEFT** until the Green LED blinks.
 - ◆ If the Red LED blinks, turn the tuning switch **RIGHT** until the Green LED blinks.
 - ◆ You can stop the blinking Green LED by pressing the **Tune** button again or by waiting until the end of the 90 second tuning period.
 - ◆ A solid Yellow LED indicates Power to the reader.
5. If you cannot attain a blinking Green LED, the reader is probably too close to metal. Set the Environment two-position slide switch to the **DOWN** position (**< 20 mm distance from metal**).
6. Repeat the Step 5 to tune the reader until the Green LED blinks.
7. Install the reader cover.
8. The SWH-2400 is now tuned and set for optimal read-range for its environment. If new metal components are introduced into the read range field, you may need to re-tune the reader. Repeat the tuning procedure.

NOTE

If the Green and Red LEDs are wired to the controller during tuning, both LEDs may be illuminated, making it difficult to distinguish which LED is blinking.

If necessary, you can correct this condition in two ways:

- ◆ Temporarily remove the LED drive wires from pins 7 and 8 before tuning. When tuning is successful, reconnect the LED wires and attach the cover.
- ◆ Initiate a Manual Action Unlock if the reader is associated with a door or gate.

MODEL SWH-2400 TECHNICAL SPECIFICATIONS

Agency Certifications:	FCC Part 15, CE, RoHS
Minimum Wiring:	5 Conductors including one LED
Recommended Cable:	18 AWG Stranded, Shielded 500 ft. (150 m) 22 AWG, Stranded, Shielded 200 ft. (60 m)
Color:	Light Gray
Dimensions, approximate:	300 mm x 300 mm x 30 mm 11.81" × 11.81" × 1.18"
Environment:	Interior/Exterior, IP 65 rated for water-resistant, dust proof enclosures.
Operating Temperature Range:	-31° to 151° F (-35 ° to 67° C)
Humidity Range:	0 to 95%
Controller Communications:	Standard Wiegand Interface
Firmware Download Communications	RS485
Index of Protection:	IP 65
Power Requirements	Rated Voltage: 8- 30VDC 300 mA maximum @ 12 VDC
Read Range (Nominal):	200 mm (8 inches) (ISO 14443A/B) MIFARE 300 mm (10-12 inches) (ISO 15693) iCLASS

Read Time:	Technology Dependent Typically less than 300 milli-seconds
Terminal Block:	12 position, 3.5 mm Screw Terminals Plug-In
Open Standards Compliance:	ISO 15693 (iCLASS) ISO 14443A/B (MIFARE)

TROUBLESHOOTING

Components

TABLE 5. Troubleshooting SWH-2400 Components

Condition	Possible Solutions
None of the LEDs are on.	Check the following: <ul style="list-style-type: none">■ Power is supplied to the reader.■ Connections at interface connector pins 3 (+VDC) and 2 (Ground) are secure and well connected.
The door does not open when a qualified credential is presented.	Verify that the door strike is wired correctly. Verify that the access credential has been entered and that the reader has been properly configured in the C•CURE 800 or 9000 system.
The Green LED does not operate as expected.	Disconnect the wire from pin 7 (Green LED) and connect pin 7 to pin 2 (Ground). If the Green LED is now on, the reader is good and the connection to the reader is defective. If the green LED does not light, replace the reader.
The Red LED does not operate as expected.	Disconnect the wire from pin 8 (Red LED) and connect pin 8 to pin 2 (Ground). If the Red LED is now on, the reader is good and the connection to the reader is defective. If the Red LED does not light, replace the reader.

Condition: Inconsistent Read Range

A common environmentally related condition is inconsistent read range.

Possible Cause #1: Unstable Power Supply

The Model SWH-2400 specifications provide a voltage range and maximum current consumption. It is critical that the power supply is capable of delivering the maximum current level within the stated voltage range.

The reader usually draws less than the maximum amount of current. However, during tuning or when the reader is momentarily out of tune as the result of a disruptive object moving through the read field, it will draw up to the maximum level. If the power supply is at its maximum load or if the reader is at the end of a long cable distance from the power supply, these temporary loads can cause the reader to dip outside of its operating voltage range.

Solutions for Unstable Power Supply

1. Use a separate dedicated linear power supply for the reader, or
2. Reduce the other loads on the power supply.

Possible Cause #2: Long Cables Absorb Power

The Model SWH-2400 specifications provide a voltage range and a maximum current consumption. It is critical that the voltage at the reader be within the specified operating voltage range in all operating modes; therefore, the installing technician must measure the voltage not only when

the reader is in its quiescent mode but also make allowance for peak (worst case) operating current.

The reader generally draws less than the maximum amount of current. However, during tuning or when the reader is momentarily out of tune as the result of a disruptive object moving through the read field, it will draw up to the maximum level. If the reader is at the end of along cable distance from the power supply, these temporary loads can cause the reader to dip outside of its operating voltage range.

To understand this problem, it is important to note that 750 feet of 22 AWG cable will have a DC resistance of approximately 30 ohms.

Example:

The Model SWH-2400 operating at a nominal current draw of 190 mA represents a resistive load of approximately 60 ohms to the power supply. Therefore, the 12 VDC power supply is reduced to $60/(30 + 60) * 12$ VDC or 8 VDC at the reader, which is still within the normal operating voltage range of the reader and operation should be normal. See Figure 9.

However, if the antenna is temporarily de-tuned by a metal object such as a laptop moving into the vicinity, the power drain can be increased by up to 50%. Therefore, the current drain may briefly increase to as much as 340 mA, representing a resistive power load of approximately 35 ohms.

The voltage at the reader now becomes $35/(30 + 35) * 12$ VDC = 6.5 VDC which is significantly outside the operating voltage range of the reader and likely to cause malfunction. See Figure 10.

Power Supply/Cable/Reader
Relationship @ Nominal

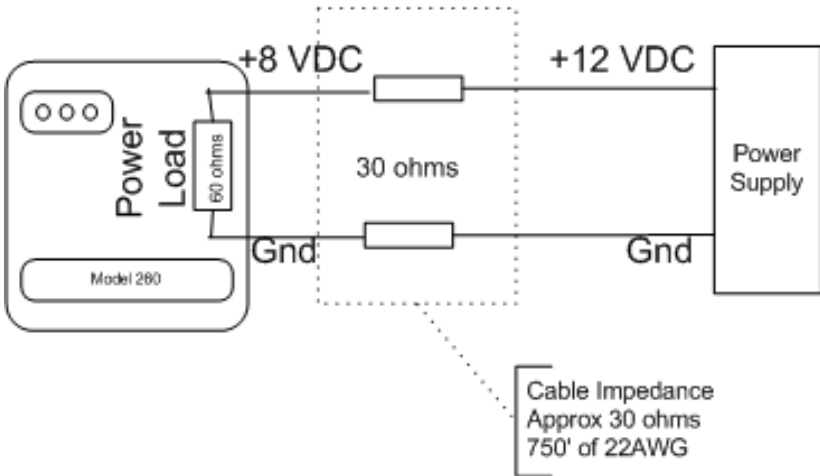

FIGURE 9. Nominal Power Supply/Cable Reader

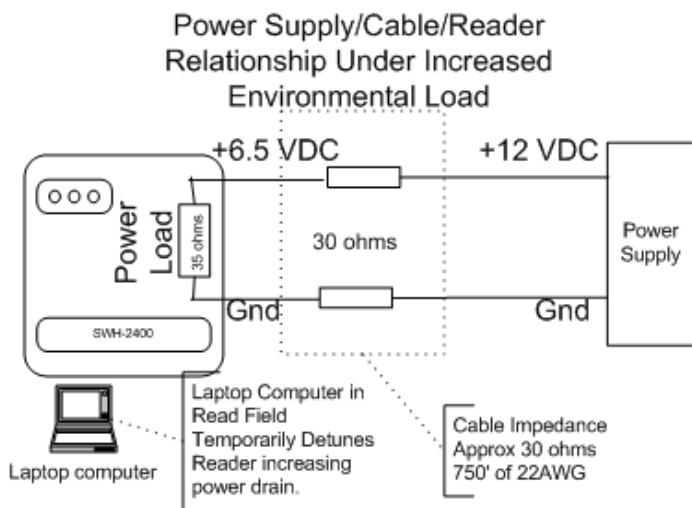

FIGURE 10. Increased Power Supply/Cable Reader Load

Solutions for Long Cables that Absorb Power

1. Use a separate dedicated linear power supply for the reader; or
2. Reduce the other loads on the power supply, or
3. Use heavier gauge cable from the power supply to the reader, or
4. Locate the power supply closer to the reader, if possible.

Possible Cause #3: Noisy Power Supply

Switching power supplies generate a great deal of spurious noise across a wide and unpredictable range of frequencies. This noise is coupled into the power cables and can interfere with the RF communications of the reader, especially if the harmonics of the switching frequency fall into the read frequency range.

In addition, switching power supply noise levels and noise frequencies can shift dynamically with load and positioning. So a noise level can interfere with read range at one time and then dissipate temporarily when overall power loads dynamically shift downward or upward.

These noise levels can be further amplified and coupled to any reader if coiled power wiring is hung in the vicinity of the reader or allowed to run parallel to the reader antenna coil.

Solutions for Noisy Power Supply

1. Replace the power supply with a linear power supply.
2. Replace the power supply with another switching power supply. (This fix may work; however, it is not recommended because of the dynamic nature of the noise).
3. Uncoil any wire in the read range vicinity of the reader, and/or
4. Run all power and data lines perpendicular to the reader coil. See diagrams below.

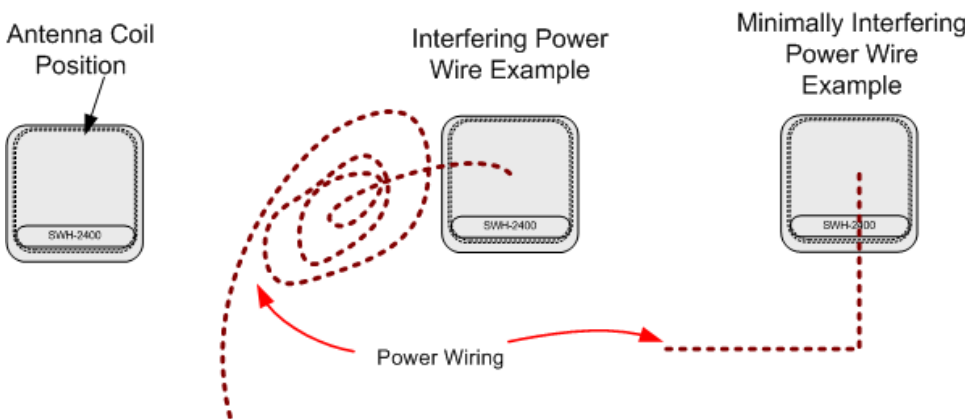

FIGURE 11. Fixing Noisy Power Supply

POSSIBLE CAUSE #4: CONDUCTIVE OBJECTS IN THE FIELD

The Model SWH-2400 is designed to operate and be tunable with good performance, even when the reader is mounted directly on a metallic surface.

However, conductive objects in the field can cause intermittent and unpredictable effects on the field characteristics of the reader. These objects can be temporary or permanent.

- **Temporary** - Temporary objects pass through the field such as a laptop computer in the briefcase of a user standing near the reader. The effect of these objects lasts as long as the object is in the vicinity of the field. However, during that time, the dynamics of field shape and consequent range performance can vary by as much as an order of magnitude (e.g. factor of 10x) with slight changes in the position of the object.
- **Permanent** - Permanent objects are usually embedded in an otherwise RF permeable wall, for example: metal stud braces in wood framing; metal studs over wall board; reinforcing bar inside concrete or masonry; small mirrors on the wall surface near the reader; and other small to medium sized metal objects permanently positioned or affixed within the field of the reader.

The read range can be affected by the orientation of the card to the antenna. The best performance occurs when the antenna in the card is perpendicular to the signal from the reader.

Solutions for Conductive Objects in the Field

For temporary objects

1. Remove the object from the field, or
2. Retry the credential read.

For permanent objects

1. Remove the object (unlikely fix), or
2. Move the position of the reader a few inches, or
3. Place a conductive surface (foil or metal plate) directly behind the reader.

Radio and Television Interference

This equipment has been tested and found to comply with the limits for a digital device, pursuant to Part 15 of the FCC rules. These limits are designed to provide reasonable protection against harmful interference when the equipment is operated in a commercial environment. This equipment generates, uses, and can radiate radio frequency energy and, if not installed and used in accordance with the instruction manual, may cause harmful interference to radio communications. Operation of this equipment in a residential area is likely to cause harmful interference, in which case the user will be required to correct the interference at his own expense.

This device complies with Part 15 of the FCC rules. Operation is subject to the following two conditions: (1) This device may not cause harmful interference, and (2) this device must accept any interference received, including interference that may cause undesired operation.

In order to maintain compliance with FCC regulations, shielded cables must be used with this equipment. Operation with non-approved equipment or unshielded cables is likely to result in interference to radio and television reception.

Caution: Changes or modifications not expressly approved by the manufacturer could void the user's authority to operate this equipment.

CANADIAN RADIO EMISSIONS REQUIREMENTS

This digital apparatus does not exceed the Class A limits for radio noise emissions from digital apparatus set out in the Radio Interference Regulations of the Canadian Department of Communications.

Le present appareil numerique n'emet pas de bruits radioelectriques depassant les limites applicables aux appareils numeriques de la class A prescrites dans le Reglement sur le brouillage radioelectrique edicte par le ministere des Communications du Canada.

CE MARKING

Hereby, Software House declares that this equipment, if used according to the instructions, is in compliance with the essential requirements and other relevant provisions of the RTTE Directive 1999/5/EC. For use in all countries of the EU.

A Declaration of Conformity exists for the following Software House Multi-technology readers:

SWH-4100	SWH-2100	SWH-1100	SWH-2000
SWH-5100	SWH-4200	SWH-3100	SWH-2400
SWH-1000	SWH-3000	SWH-5000	

To obtain a copy, contact Software House and request the “Declaration of Conformity” document for Multi-technology readers.

Software House
70 Westview Street
Lexington, MA 02421 U.S.A.

In case of alteration of the product, not agreed to by us, this declaration will lose its validity.

This symbol indicates proof of conformity to applicable European Economic Community Council directives and harmonized standards published in the official journal of the European Communities.





Copyrights and Trademarks

C•CURE®, Software House®, and iSTAR® are registered trademarks of Sensormatic Electronics Corporation.

Certain Product names mentioned herein may be trade names and/or registered trademarks of other companies. Information about other products furnished by Software House is believed to be accurate. However, no responsibility is assumed by Software House for the use of these products, or for an infringement of rights of the other companies that may result from their use.

SWH-2400 Reader Quick Start Installation Guide

Document Number: UM-106

Revision: A0

Release Date: August 2007

This manual is proprietary information of Software House. Unauthorized reproduction of any portion of this manual is prohibited. The material in this manual is for information purposes only. It is subject to change without notice. Software House assumes no responsibility for incorrect information this manual may contain.

Copyright ©2007 Sensormatic Electronics Corporation.

All rights reserved.